

AIR EXCELLENT

200 Series distribution boxes, type DB208



The distribution box is an important part of the Air Excellent distribution system. It controls the air capacity of the duct runs within the system. To control the air flow per duct run, adjustable air flow restrictors are mounted at the ductwork connections in the distribution box.



Introducing box type DB208

The 200 Series DB208 is a compact, lightweight, plastic distribution box that comes standard with 8 connections but can be extended as desired. The DB208 distribution box is ideal for residential buildings that require lower air volumes or buildings that have limited installation space.

Horizontal and vertical extensions

A keen feature is the possibility of connecting multiple boxes. The DB208 can be vertically extended becoming a stacked-configuration with 16 ductwork connections. This makes the DB208 a very scalable solution.

Mass flow adaptors

The mass flow ductwork can be connected vertically with stepped adaptors allowing 125/150/160 and 180 mm connections or with a 100/125 mm stepped adaptor.

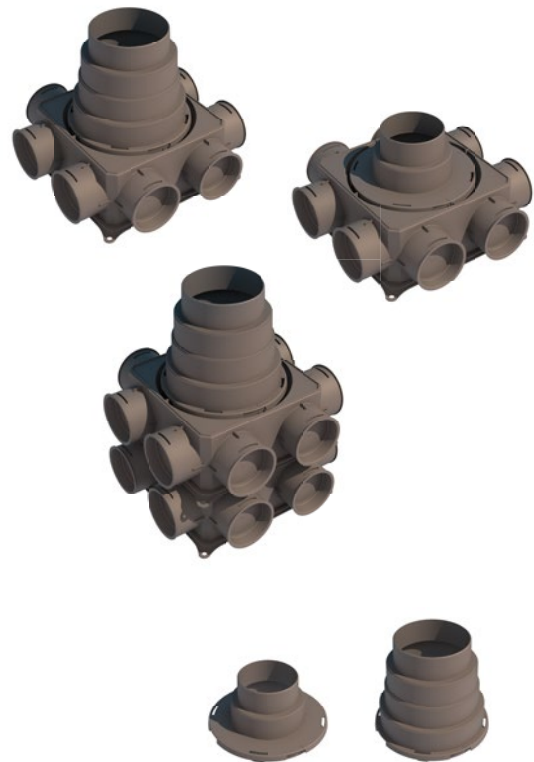

AIR EXCELLENT

200 Series distribution boxes, type DB208

Features & performance

- Standard 8 ductwork connections
- Extended configurations possible
- Stepped mass flow adaptors for 100/125 mm and 125/150/160 and 180 mm available
- Air flow adjustable by the standard 12-stage Air Excellent restrictors
- All Air Excellent ductwork types can be connected
- Tested according to TÜV SÜD Standard TAK 01-2013 (system pressure: +2000 Pa/-2000 Pa)
- Easy to clean the system and re-arrange the flow restrictors (e.g. renovation)
- Made of virgin raw PP materials



200 Series DB208			
Box configuration	1	2	3
Qv (Volume) [m ³ /h]	Δp (Pressure Loss) [Pa]		
50	1,0	1,0	1,0
75	1,5	1,5	1,5
100	2,0	2,0	2,0
125	3,0	3,0	3,0
150	5,0	5,0	5,0
175	6,5	6,5	6,5
200	8,0	8,0	8,0
225	9,0	9,0	9,0
250	10,0	-	10,0
300	-	-	14,0
350	-	-	16,0

Figures are based on measurements by the TÜV SÜD.

- 1 with stepped mass flow adaptor 125–180 mm
- 2 with stepped mass flow adaptor 100–125 mm
- 3 vertical extended configuration

AIR EXCELLENT

200 Series distribution boxes, type DB208



ubbink

Build smart.

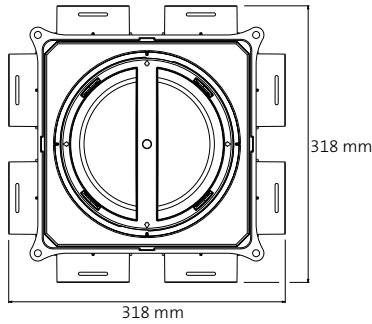

DB208

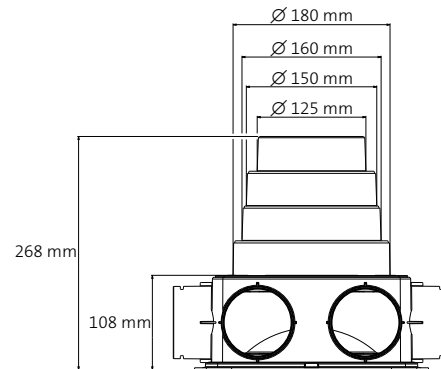

DB208 with stepped mass flow adaptor 125-180 mm

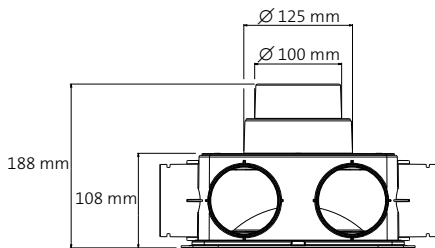

DB208 with stepped mass flow adaptor 100-125 mm

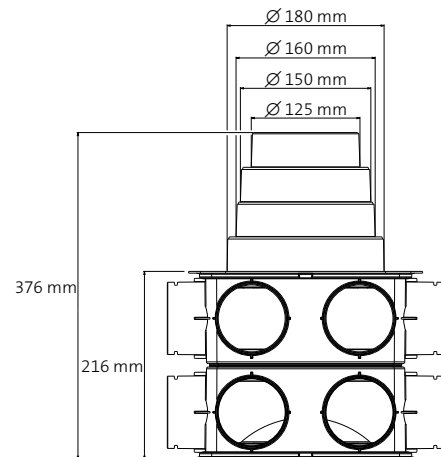

DB208 vertical extended configuration

© 2019 - Ubbink Centrotherm Group | Content is subject to change without notice | Availability and configurations may differ per country | UB-2019-09-V01-UK-EN